



**IMPORTANT NOTE:** Luminaire must be installed and grounded in accordance with the National Electrical Code (NEC) and local codes.

All conduit entries must be sealed from moisture. Use appropriate sealing material on conduit fittings and conduit closure plugs.

Rough-in-Box (RiB) housing **MUST** be installed so that the front face at the box is flush or slightly forward with the finished wall surface. Rough-in-Box (RiB) housing provided with (3) 1/2" NPT closure plugs and (4) knockout membranes.

Luminaire is IC and Non-IC rated. Luminaire is wet location listed and suitable for mounting within 3ft of ground.

Suitable for all types of construction including poured concrete construction and in stud wall applications.

Suitable for through wiring: max. of (4) No. 12 AWG conductors (plus ground) rated for 90°C.

**MAINTENANCE:** To assure proper operation and efficiency, lens must be kept clean and free of dirt, dust, leaves, trash and mineral deposits from water. A regular schedule maintenance program is recommended.

**NOTE:** Save these instructions for future reference



### INSTALLATION IN STUD WALL CONSTRUCTION

**IMPORTANT NOTE:** Internal supports, temporary cover plate, and vinyl label must remain in place during RiB housing installation.

1. Determine housing mounting bracket orientation, i.e. 1/2" thick drywall or 5/8" thick drywall (fig. 1).
2. Install the (2) RiB housing mounting brackets provided using the (4) 8-32 Hex screws provided (fig. 1).

3. Secure the RiB housing mounting brackets using fasteners (by others) to support studs (fig. 2).
4. Connect conduit to RiB housing (fig. 2).
5. Remove and retain vinyl label, temporary cover plate, and internal supports. Pull wires for electrical connections to be made later.
6. To protect RiB housing during construction, reinstall internal supports, temporary cover plate, and vinyl label.

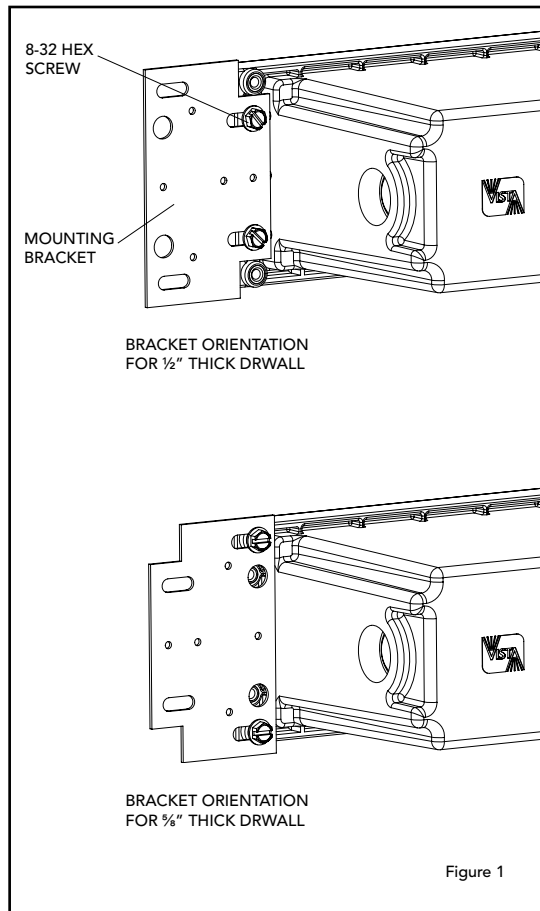

Figure 1

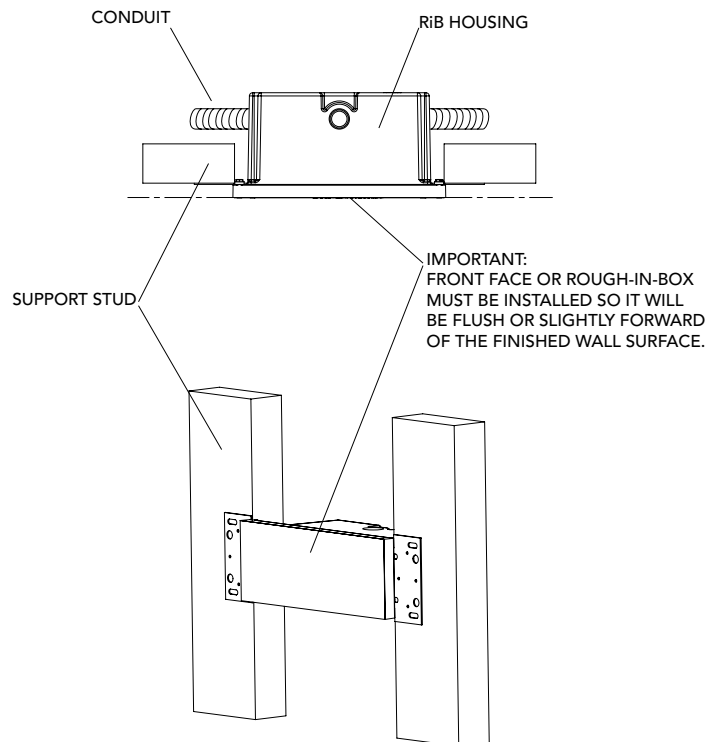

Figure 2





### INSTALLATION IN POURED CONCRETE CONSTRUCTION

**IMPORTANT NOTE:** Internal supports, temporary cover plate, and vinyl label must remain in place during pouring and curing of concrete (fig. 3).

1. Install (4) threaded 8-32 rods (supplied) into RiB housing by piercing through vinyl label in specified location. Hand tighten until secure.
2. Attach RiB housing to pour form using (4) wing nuts provided so the front face of the RiB housing will be flush with the finished surface (fig. 4).
3. Connect conduit to RiB housing (fig. 4).
4. Pour concrete.

**NOTE:** Do not pump or drop concrete directly on top of the RiB housing (fig. 4).

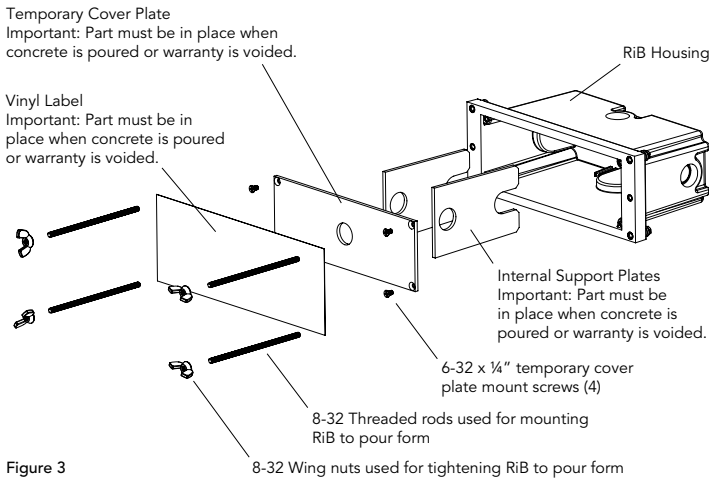

Figure 3

5. Remove the wing nuts from threaded rods before removing pour form.
6. Remove and retain vinyl label, temporary cover plate, and internal supports. Pull wires for electrical connections to be made later.
7. To protect RiB housing during construction, reinstall internal supports, temporary cover plate, and vinyl label.

**NOTE:** All doors sit proud from final surface. Flush Tray available for Glass Border only.

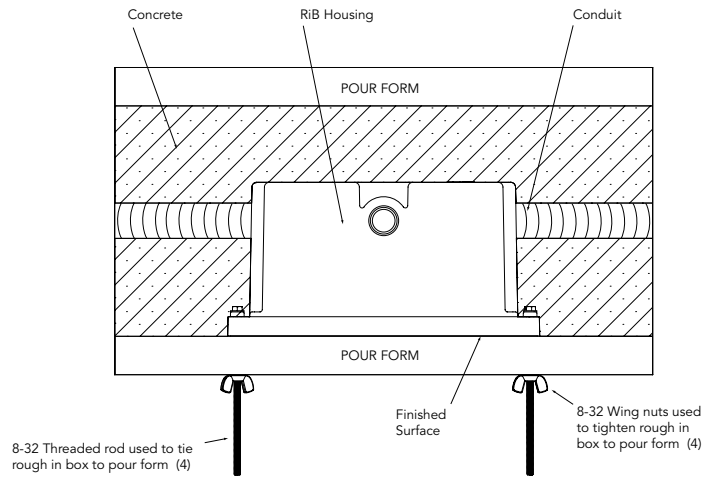
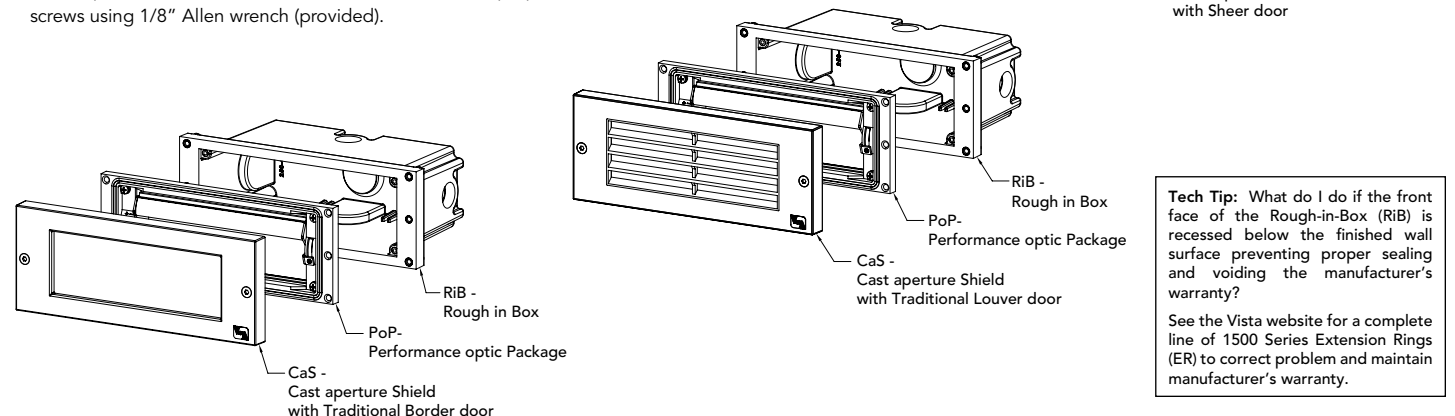

Figure 4

### OPTIC PACKAGE AND APERTURE INSTALLATION

1. To prevent electrical shock, turn main power off at circuit breaker.
2. Before continuing, remove vinyl label, temporary cover plate, and internal supports.
3. Using wire nuts (provided), make wire connections of the performance optic package (PoP) to the supply conductors.
4. Install Performance optic Package (PoP) to RiB housing using (4) 6-32 screws (provided), making sure gasket is seated properly. Orient PoP correctly to ensure proper light direction.
5. Turn on main power at circuit breaker and adjust hot aiming using 1/16" Allen wrench (provided).
6. Install aperture shield, making sure the gasket is seated properly. Tighten (2) 8-32 screws using 1/8" Allen wrench (provided).



**Tech Tip:** What do I do if the front face of the Rough-in-Box (RiB) is recessed below the finished wall surface preventing proper sealing and voiding the manufacturer's warranty?

See the Vista website for a complete line of 1500 Series Extension Rings (ER) to correct problem and maintain manufacturer's warranty.

