



INSTALLATION INSTRUCTIONS

IMPORTANT NOTE:

- Luminaire must be installed and grounded in accordance with the National Electrical Code (NEC) and local codes.
- All conduit entries must be sealed from moisture. Use appropriate sealing material on conduit fittings and conduit closure plugs.
- Luminaire is wet location listed and suitable for mounting in-grade.
- Suitable for all types of construction including poured concrete construction and in soil applications.
- Suitable for through wiring: Max. of (4) No. 12 AWG conductors (plus ground) rated for 90°C.

WARNING: Debris must be kept clear from top and interior of in-grade fixtures. Excessive heat could occur that may create a fire hazard and/or harm the fixture components. Specific attention must be made to never install in-grade fixtures in mulch, wood chips or other potentially ignitable materials. Failure to do so will void the warranty and may result in serious injury and/or damage to the fixture and/or property.

SAFETY WARNING: Luminaire can become very hot depending on the lamp wattage used. Lens and housing around the lamp can become hot enough to blister hands. Particular care should be taken not to locate luminaires where small children can reach them if high wattage lamps are used.

MAINTENANCE: To assure proper operation and efficiency and to prevent luminaire overheating, lens must be kept clean and free of dirt, dust, leaves, trash and mineral deposits from water. A regular schedule maintenance program is recommended.

NOTE: Save these instructions for future reference.



INGRADE SOIL INSTALLATION

IMPORTANT NOTE: If you are using an HID self reflector lamp in this luminaire, an integrated ballast must be used. Consult Vista catalog for ordering information. Temporary cover plate and vinyl label must remain in place during housing installation.

PRECAUTION: Adequate drainage must be provided during installation. It is recommended the luminaire be surrounded by 3" to 4" of pea gravel or sand to assure proper drainage. Top of luminaire must be above grade so rain and irrigation water will not accumulate for long periods of time.

1. To prevent electrical shock, turn main power off at circuit breaker.
 2. Dig hole approximately 15" in diameter to a depth suitable to make top of temporary cover plate 3/4" above grade (see fig. 1). Pea gravel or sand is recommended for seating the luminaire housing.
 3. Connect conduit to housing. UL listed flexible conduit is recommended for in and out connections to ease fixture positioning.
 4. Plug any unused NPT holes with closure plugs (provided).
 5. Position fixture within hole and back-fill with pea gravel or sand.
- NOTE:** For a more secure installation, rebar bracing is recommended. Drill a small hole in the stiffeners located on the side of the luminaire. Position rebar (by others) onto adjacent stiffeners and secure with wire-ties (see fig. 1).
6. To pull supply conductor wiring, remove and retain vinyl label and temporary cover plate.
 7. Remove and retain junction box lid.
 8. Pull electrical supply wires (line in) through conduit and junction box. Pull wires and make a 6" loop, long enough for manual connections with safety connectors (4" to 6" above the top rim of junction box).
 9. Stuff wire loop into junction box. Reinstall junction box lid, temporary cover plate, and vinyl label.

NOTE: Failure to remove all dirt and debris from gasket sealing surface may cause leakage and void warranty.

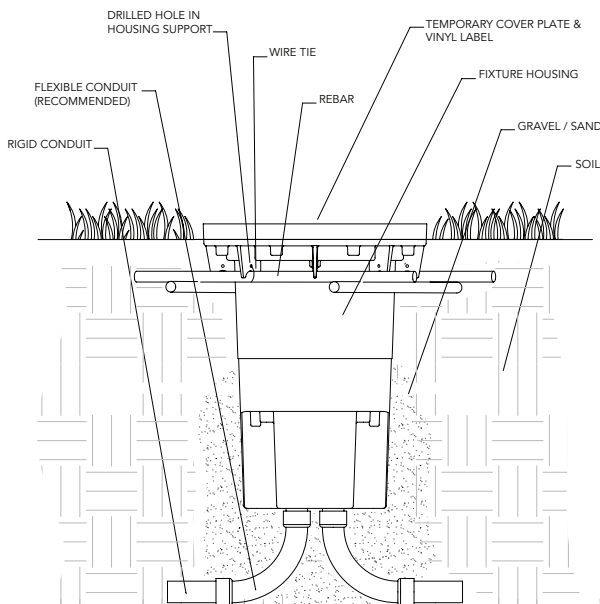

Figure 1

CONCRETE POUR INSTALLATION

IMPORTANT NOTE: Temporary cover plate and vinyl label must remain in place during housing installation.

PRECAUTION: Vinyl label and top of temporary cover plate must be at finished grade.

1. To prevent electrical shock, turn main power off at circuit breaker.
2. Fit provided concrete-guard plugs over all eight bosses with threaded inserts beneath the flange in order to prevent poured concrete from back filling threaded holes and hindering a secure water tight seal of the lens cover.

NOTE: Failure to properly install concrete guard plugs over bosses with threaded inserts will void warranty.

3. Dig hole approximately 15" in diameter to a depth suitable to make top of fixture flush to grade (see fig. 2). Pea gravel or sand is recommended for seating the luminaire housing.
4. Connect conduit to housing. UL listed flexible conduit is recommended for in and out connections to ease fixture positioning.
5. Plug any unused NPT holes with closure plugs (provided).
6. Position fixture within hole and back-fill with pea gravel or sand.
7. To keep housing from floating, affix to rebar or grid-wire using standard masonry methods.
8. To pull supply conductor wiring, remove and retain vinyl label and temporary cover plate.
9. Remove and retain junction box lid.
10. Pull electrical supply wires (line in) through conduit and junction box. Pull wires and make a 6" loop, long enough for manual connections with safety connectors (4" to 6" above the top rim of junction box).
11. Stuff wire loop into junction box. Reinstall junction box lid, temporary cover plate, and vinyl label.
12. Pour concrete at least 2" thick. Trowel concrete so that it is even with vinyl label. Allow concrete to cure.

NOTE: Failure to remove all dirt and debris from gasket sealing surface may cause leakage and void warranty.

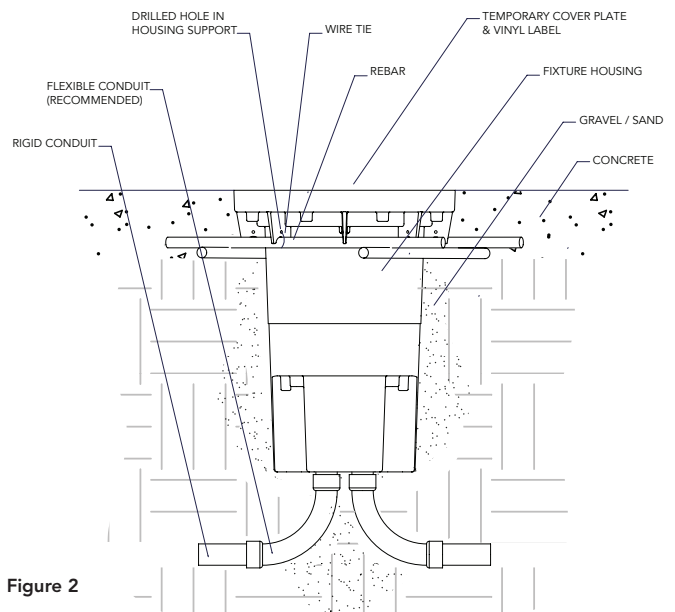

Figure 2

Vista Professional Outdoor Lighting reserves the right to modify the design and/or construction of the fixture shown without further notification.

BALLAST ASSEMBLY, OPTIC ASSEMBLY AND FIXTURE COVER INSTALLATION

1. To prevent electrical shock, turn main power off at circuit breaker.
2. Remove vinyl label and temporary cover plate.
3. Remove junction box lid.
4. Pull supply conductor wire loop out of junction box, cut at center and strip leads.
5. Using the silicone filled wirenuts (provided), connect the load conductors located within the junction box to the supply conductors (see fig. 3).

INSTRUCTIONS FOR SEALING WIRING COMPARTMENT:

NOTE: Failure to properly wire and encapsulate wire compartment will void product warranty.

6. Stuff the silicone filled wirenuts to the bottom of junction box.
 7. Use Mastic (provided), to seal the conduit entries from inside wire compartment to ensure the sealant (see below) does not flow down into the conduit.
 8. Remove Sealant Pouch (provided), from protective cover. Grasp both sides of the sealant pouch and pull until there is no barrier between both solutions in the pouch.
 9. Mix the sealant by alternately squeezing each end of the sealant pouch, moving the sealant back and forth until the solutions are completely mixed together.
 10. Cut off the corner of the sealant pouch and immediately pour into the wiring compartment completely covering the wirenuts (see fig. 3). Allow sealant to dry for approximately 20 minutes.
 11. Replace junction box lid.
 12. Plug the male connector of the HID ballast module into the female connector located at bottom of the rough-in section.
 13. Place HID ballast module into lower portion of the rough-in section and secure with 3 HID ballast module mount screws (provided).
 14. Plug male connector of lamp reflector module into female connector of HID ballast module and position the lamp reflector module into the rough-in section housing.
 15. Secure in place using 2 brass thumb screws (provided).
 16. Install lamp with correct wattage and type marked on fixture label.
- NOTE:** Do not touch lamp with bare hands; use a soft cloth.
17. To aim reflector module, loosen the 3 adjustment thumb screws. Rotate and tilt reflector module to desired position and lock in place by tightening thumb screws.
 18. Clean gasket and gasket sealing surface.
 19. Position gasketed lens onto rough-in section sealing surface.
 20. Place lens cover onto fixture. Align holes with coinciding holes of the rough-in section. Using 8 stainless steel screws (provided), evenly tighten screws.
 21. Supply power to the luminaire and check for proper operation.

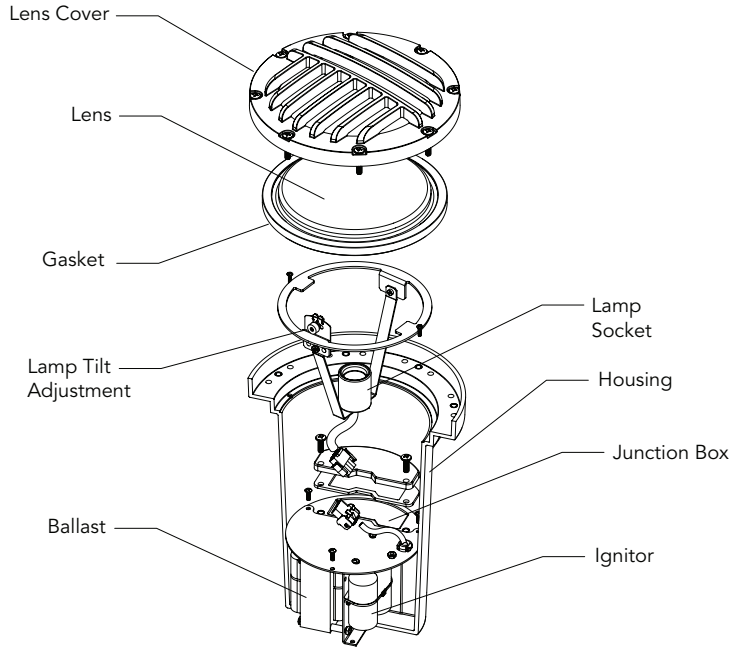

Figure 3

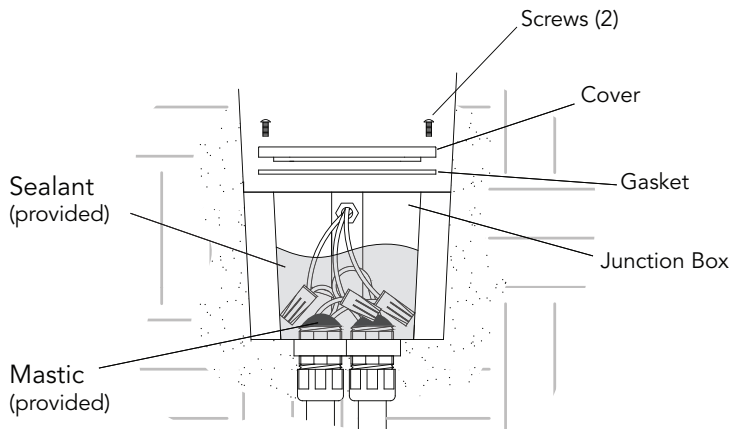

Figure 4

Vista Professional Outdoor Lighting reserves the right to modify the design and/or construction of the fixture shown without further notification.