



**PROFESSIONAL
OUTDOOR LIGHTING**

SPECIFICATION SHEET

Type:

Model:

Project:

MODEL 1505 Extension Ring ER-1, ER-2, ER-3 Architectural Series • Accessories

ACCESSORY SPECIFICATIONS:

NOTE: When the sealing surface of the 1505 RiB housing is recessed below the finished grade, preventing proper sealing of the fixture, an Extension Ring(s) (ER-1, 2, or 3) must be used to complete the installation.

Constructed of die-cast, copper-free aluminum with a black powder-coat finish. A continuous silicone gasket insures a weather-tight seal. Includes four (4) 8-32 stainless steel screws.

The **ER-1** is a single ring extension to accommodate a recessed measurement of 0" - .375".

The **ER-2** is two ring extension to accommodate a recessed measurement of .375" - .75"

The **ER-3** is a three ring extension to accommodate a recessed measurement of .75" - 1.125".

All Vista accessories are [MADE IN THE U.S.A.](#)

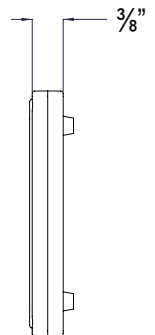
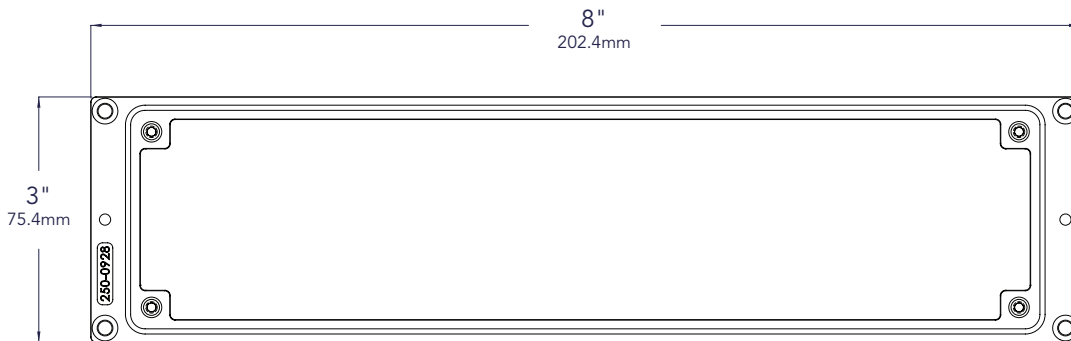
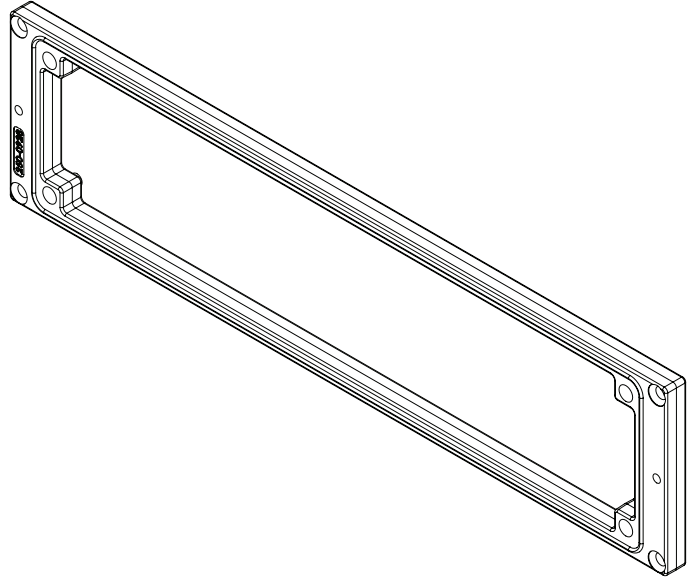

Vista Professional Outdoor Lighting reserves the right to modify the design and/or construction of the fixture shown without further notification.